



Speedo With Telltales and Display 85mm

Tech Support 1-800-265-1818
<http://usa.vdo.com>

Instruction Sheet # A2C59519491

Rev 04-2011

Gauge Installation:

1. Select the desired mounting location of the instrument.
2. Depending on your mounting situation it might be necessary to configure the gauge before installation. See page 2 - Setting up the Speedometer.
3. Mount the gauge and secure with the VDO Spin-Lok™ Clamp.

(See page 5 for mounting options and instructions)

Wiring the Gauge (Illustration A):

1. Route wires from the instrument to:
 - (a) the battery (+) constant power after the fuse box or user supplied in-line fuse – 5 amp fast-blow.
 - (b) the battery (+) after the ignition switch and after the fuse box or user supplied in-line fuse – 1 amp fast-blow.
 - (c) the light switch after the fuse box or user supplied in-line fuse -1 amp.
 - (d) a good, dedicated ground location.
 - (e) Signal source - Hall Effect sender, Inductive sender, or Electronic control box.
2. Connect the harness according to the following wiring Matrix:

Pin	Description
1	Red - Battery constant (+12 / 24 V)
2	Black - Ground
3	Blue/Black - Sender Signal (-)
4	Brown - Battery switched (+12 / 24 V)
5	Green - Sender Signal (+)
6	Blue/Red - Illumination (+)
7	Not Connected
8	Not Connected
Note - Use 18 AWG for wire harness	

Merchandise warranted against defects in factory workmanship and materials for a period of 24 months after purchase. This warranty applies to the first retail purchaser and covers only those products exposed to normal use or service. Provisions of this warranty shall not apply to a VDO product used for a purpose for which it is not designed, or which has been altered in any way that would be detrimental to the performance or life of the products, or misapplication, misuse, negligence or accident. On any VDO part or VDO product found to be defective after examination by manufacturer, manufacturer will only repair or replace the merchandise through the original selling dealer. Manufacturer assumes no responsibility for diagnosis, removal and/or installation labor, loss of vehicle use, loss of time, inconvenience or any other consequential expenses. The warranties herein are in lieu of any other expressed or implied warranties, including any implied warranty of merchantability of fitness, and any other obligation on the part of manufacturer, or selling dealer.

Read these instructions thoroughly before installation. Do not deviate from assembly or wiring diagram. Always disconnect battery ground before making any electrical connections.

IMPORTANT: Mounting dimensions vary for different gauges. Please be certain to follow the instructions for your specific gauge.

Parts List		
Item	Description	Qty
1	85mm Gauge	1
2	Spin-Lok™ Clamp	1
3	Gasket	1
4	8 pin Harness	1
5	14 pin Harness	1
6	Push-button	1
7	Instruction Sheet	1

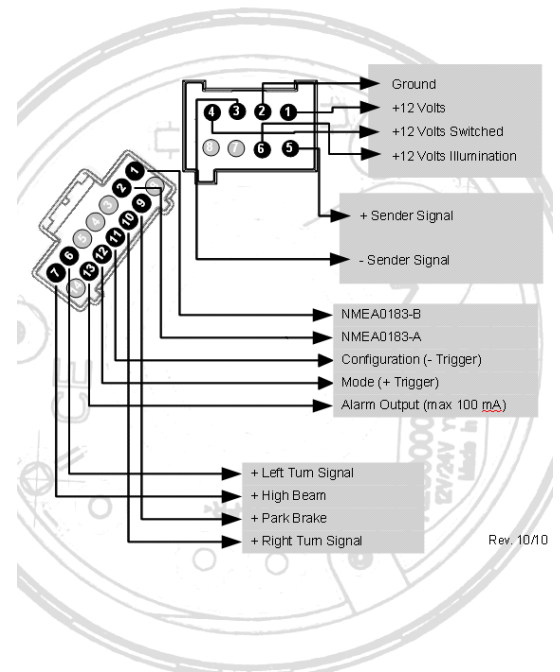

Rev. 10/10

Illustration A

Speedo With Telltales and Display 85mm

Tech Support 1-800-265-1818
http://usa.vdo.com

Instruction Sheet # A2C59519491

Rev 04-2011

Programming the Speedometer (Illustration B):

Operation Basics:

Short Press (< 2sec.) - Long Press (> 2sec.)

The Configuration button must be connected before programming can be done.

The display will return to normal operation if a button is not pressed for 30 seconds. Any settings you have made will not be saved.

Setting the Speedometer Input:

1. With the ignition switch off, hold in the Configuration button
2. Turn ignition on
3. Release the Configuration button
4. "INPUT" will appear on the display
5. Long press to get to the Input setting screen
6. Short press to cycle through "FREQUE" or "NMEA".
NOTE: NMEA input requires no calibration.
7. Long press to exit input setting
8. "INPUT" will appear on the display

Calibrating the Speedometer (FREQUE Input)– Autocal or Manual

Autocalibration (Autocl):

The auto-calibration function can be used successfully on a road with the distance of one mile accurately designated. The road does not have to be straight.

1. While in configuration mode (Refer to step 1-3 above) Short press to get to the "Autocl" setting screen.
2. Long Press to enter the autocal menu– "button" will appear.
3. When you are ready to begin your calibration run, short press the button again. "000000" will appear on the display.
4. Drive the reference distance of one mile (or 1 kilometer).
NOTE: As you drive this distance, the pulses will be displayed and the needle will move. If the Speedo is not counting pulses, no useable impulse is being detected.
5. After 1 mile, Short press. The number of pulses counted during the calibration run will be displayed.
6. Long press to save the pulse count and exit the autocalibration ("PULSE" will appear on the display).
7. Turn off ignition. The Speedometer is now programmed.

Pin	Description
1	Blue - NMEA0183-B (optional, GPS)
2	White - NMEA0183-A (optional, GPS)
6	Black/Red - Left Turn (+ Trigger)
7	Black/White - High Beam (+ Trigger)
9	Yellow - Park Brake (+ Trigger)
10	Orange - Right Turn (+ Trigger)
11	Green/Black – Configuration (- Trigger)
12	Green/Red - Mode (+ Trigger)
13	Red - Alarm Output(max 100 mA)
3-5, 8, 14	unassigned

NOTE: The Push-button supplied is to be used as a:

- a) **Configuration** button to set up the speedometer before use.
- b) **Mode** button for operation of the speedometer during normal use.

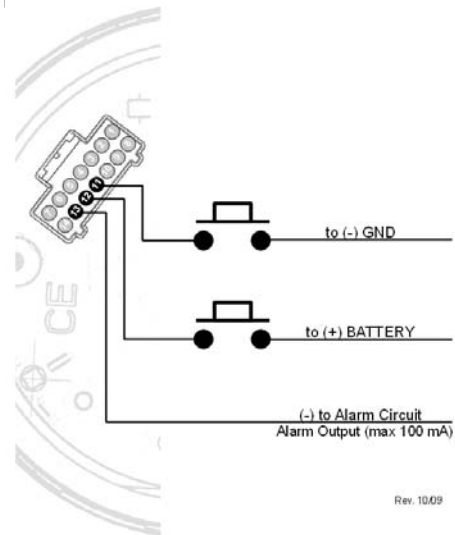

1. With the ignition switch off, hold in the Configuration button.

Illustration B

Speedo With Telltales and Display 85mm

Tech Support 1-800-265-1818
http://usa.vdo.com

Instruction Sheet # A2C59519491

Rev 04-2011

2. Turn ignition on.
3. Release the Configuration button.
4. "INPUT" will appear on the display
5. Short press twice - "PULSE" will appear on the display
6. Long press to get to the pulse setting screen
7. Short press will increase the value of the flashing number by 1.
8. Long press to move to the next position.
9. Continue until right most digit is set.
10. Long press to exit pulse setting.
11. "PULSE" will appear on the display.
12. Turn off ignition.

The Speedometer is now programmed. The Configuration button can be disconnected and connected to be used as the Mode button.

Set Unit and Alarm Threshold:

1. With the ignition switch off, hold in the Mode button
2. Turn ignition on
3. Release the Mode button
4. "UNIT" will appear
5. Long press to enter UNIT menu
6. Short press to change the clock format
12 hour am/pm - 24 hour
7. Long press to return to UNIT menu
8. Short press to show "WARN" on the display
9. Long press to enter WARNING menu
10. Short press to set Speed warning limit.
11. Short press will increase the value of the flashing number by 1 - Long press will move to the next position
12. Continue until right most digit is set.
13. Long press to exit.
14. Turn off ignition.

The Warning Icon in the gauge will illuminate and the Alarm Output (Pin 13 of 14 pin connector) will trigger to ground when the Speed exceeds this limit.

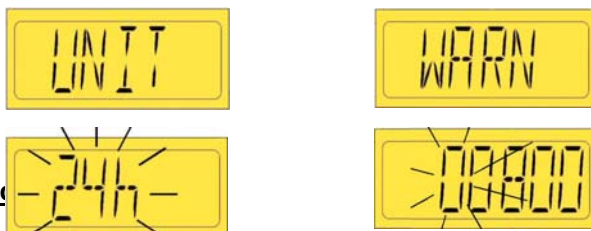

In normal operating situations, Short press of the MODE button will cycle through:

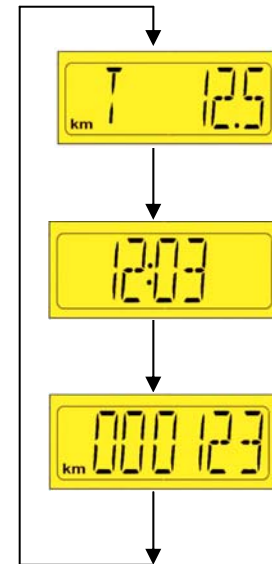

Reset the Trip Distance:

1. Press the Mode key repeatedly until the trip distance is displayed.



2. Press and hold Mode key to reset.



Setting the Time:

1. Press the Mode key repeatedly until the clock is displayed.
2. Long press the Mode button to

Speedo With Telltales and Display 85mm

Tech Support 1-800-265-1818
<http://usa.vdo.com>

Instruction Sheet # A2C59519491

Rev 04-2011

enter clock set mode.



3. Short press will increase the value of the flashing number by 1

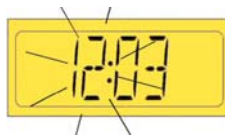

4. Long press to move to the next position
5. When finished, Long Press to return to clock display

Note if Pin 1 - Battery (+12 / 24 V) – of the 8 pin connector is disconnected, the clock will need to be reset.

Set the Illumination intensity (1 to 10):

1. Long press the Mode button while the Odometer is displayed to enter Illumination setting.



2. Short Presses will increase the value of the flashing number by 1.



3. Long press to save the Illumination setting and return to the Odometer display screen.

Examples of Sender Types:

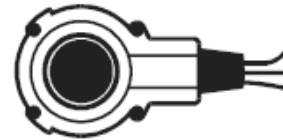

Hall Effect Sender

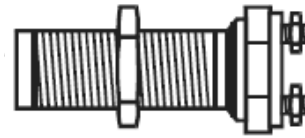

Inductive Sender



85mm

Conventional (Included)

Instrument is put into the drilled hole from the front. The maximum panel thickness is 20mm. The drilled hole must have a diameter of 86mm.

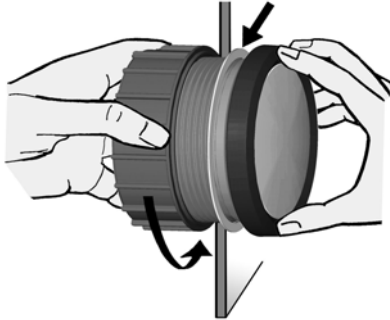

* Make sure the seal lays flat between the panel and the front ring.

For 85mm instruments, the Spin-Lok™ nut can be mounted at position A or B. This allows you two clamping depths.

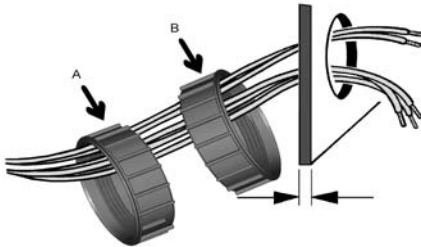

Version A
10mm

Version B
20mm

Flush (Optional)

When flush mounting (i. e., from the back so that the instrument glass and the panel form one plane), the front ring must be removed. Press on the instrument glass with both thumbs, while at the same time pulling the front ring forward from the instrument with both index fingers.

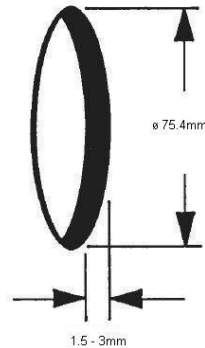

The recommended panel thickness is 1.5 to 3 mm. The drill hole must have a diameter of 75.4mm. Ensure that the installation location is level and has no sharp edges.

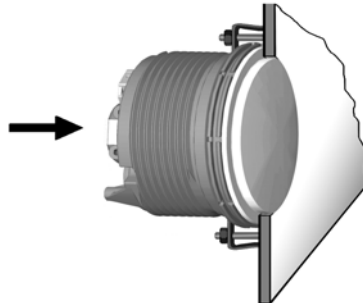

Place the flush mount seal on the instrument glass. Put the instrument into the drill hole from the back. Adjust the instrument so that the gauge is level and fasten it to the stud bolts (not included) on the rear side of the panel, using the flush mount fixing brackets.

Stud (Optional)

If you would like to omit the fastening nut, you may use the stud mount as an alternative. This is recommended if the installation location is subject to extreme vibrations.

Screw the stud bolts into the drilled holes on the rear of the instrument housing. Max. stud bolt torque is 1.5Nm.

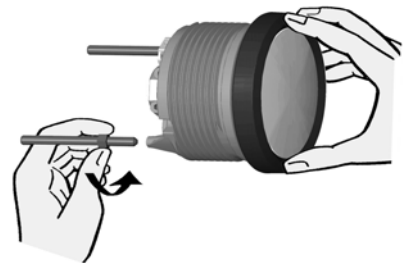

Place the bracket on the stud bolt and tighten the knurled nut. Do not over-tighten.

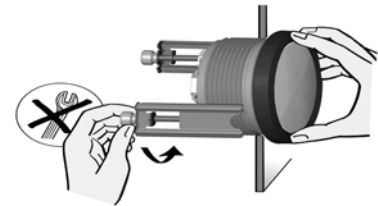

* Make sure the seal lays flat between the panel and the front ring.

